



SLC™ 500 4-Channel Thermocouple/mV Input Module

(Catalog Number 1746-NT4, Series B)

Inside.....	Page
For More Information.....	3
Hazardous Location Considerations	4
Environnements dangereux	4
Overview	5
Required Tools and Equipment	6
Electrostatic Damage.....	7
NT4 Power Requirements.....	7
Modular Chassis Considerations.....	7
Fixed Expansion Chassis Considerations.....	8
General Considerations	8
Terminal Block Removal.....	8
Module Installation and Removal.....	10
Terminal Wiring.....	11
Thermocouple Junctions.....	12
Wiring Considerations	13
Wiring Input Devices to the NT4	15
Cold-Junction Compensation (CJC)	16
Module Addressing.....	17
Channel Configuration	17
Specifications	19

Important User Information

Solid state equipment has operational characteristics differing from those of electromechanical equipment. *Safety Guidelines for the Application, Installation and Maintenance of Solid State Controls* (Publication SGI-1.1 available from your local Rockwell Automation sales office or online at <http://www.ab.com/manuals/gi>) describes some important differences between solid state equipment and hard-wired electromechanical devices. Because of this difference, and also because of the wide variety of uses for solid state equipment, all persons responsible for applying this equipment must satisfy themselves that each intended application of this equipment is acceptable.





In no event will Rockwell Automation, Inc. be responsible or liable for indirect or consequential damages resulting from the use or application of this equipment.

The examples and diagrams in this manual are included solely for illustrative purposes. Because of the many variables and requirements associated with any particular installation, Rockwell Automation, Inc. cannot assume responsibility or liability for actual use based on the examples and diagrams.

No patent liability is assumed by Rockwell Automation, Inc. with respect to use of information, circuits, equipment, or software described in this manual.

Reproduction of the contents of this manual, in whole or in part, without written permission of Rockwell Automation, Inc. is prohibited.

Throughout this manual we use notes to make you aware of safety considerations.

<p>WARNING</p> 	<p>Identifies information about practices or circumstances that can cause an explosion in a hazardous environment, which may lead to personal injury or death, property damage, or economic loss.</p>
<p>IMPORTANT</p>	<p>Identifies information that is critical for successful application and understanding of the product.</p>
<p>ATTENTION</p> 	<p>Identifies information about practices or circumstances that can lead to personal injury or death, property damage, or economic loss. Attentions help you:</p> <ul style="list-style-type: none">• identify a hazard• avoid a hazard• recognize the consequence
<p>SHOCK HAZARD</p> 	<p>Labels may be located on or inside the drive to alert people that dangerous voltage may be present.</p>
<p>BURN HAZARD</p> 	<p>Labels may be located on or inside the drive to alert people that surfaces may be dangerous temperatures.</p>

For More Information

Related Publications

For:	Refer to this Document:	Pub. No.
A more detailed description on how to install and use your SLC 500 4-Channel Thermocouple/mV Input Module.	<i>Thermocouple/mV Input Module User Manual</i>	1746-6.6.1
A more detailed description on how to install and use your SLC 500 Modular Hardware Style Control System.	<i>SLC™ 500 Modular Hardware Style User Manual</i>	1747-UM011
A more detailed description on how to install and use your SLC 500 Fixed Hardware Style Control System.	<i>SLC™ 500 Fixed Hardware Style Installation and Operation Manual</i>	1747-6.21

If you would like a manual, you can:

- download an electronic version from the internet:
www.theautomationbookstore.com
- order a printed manual by:
 - contacting your local distributor or Rockwell Automation representative
 - visiting **www.theautomationbookstore.com**
 - calling **1.800.963.9548** (USA/Canada) or **001.330.725.1574** (Outside USA/Canada)

Hazardous Location Considerations

This equipment is suitable for use in Class I, Division 2, Groups A, B, C, D or non-hazardous locations only. The following WARNING statement applies to use in hazardous locations.

WARNING



EXPLOSION HAZARD

- Substitution of components may impair suitability for Class I, Division 2.
 - Do not replace components or disconnect equipment unless power has been switched off or the area is known to be non-hazardous.
 - Do not connect or disconnect components unless power has been switched off or the area is known to be non-hazardous.
 - All wiring must comply with N.E.C. article 501-4(b).
-

Environnements dangereux

Cet équipement est conçu pour être utilisé dans des environnements de Classe I, Division 2, Groupes A, B, C, D ou non dangereux. La mise en garde suivante s'applique à une utilisation dans des environnements dangereux.

WARNING



DANGER D'EXPLOSION

- La substitution de composants peut rendre cet équipement impropre à une utilisation en environnement de Classe I, Division 2.
 - Ne pas remplacer de composants ou déconnecter l'équipement sans s'être assuré que l'alimentation est coupée.
 - Ne pas connecter ou déconnecter des composants sans s'être assuré que l'alimentation est coupée.
-

Overview

The thermocouple/mV input module receives and stores digitally converted thermocouple and/or millivolt (mV) analog data into its image table for retrieval by all fixed and modular SLC 500 processors. The module supports connections from any combination of up to four thermocouple or mV analog sensors. See the input specifications beginning on page 21 for thermocouple types, their associated temperature ranges, and the analog input signal ranges that each 1747-NT4 channel will support. Each input channel is individually configurable via software for a specific input device and provides open-circuit, over-range, and under-range detection and indication.

The module contains a removable terminal block with two cold-junction compensation (CJC) sensors. There are no output channels on the module. Configuration is done via the user program. There are no DIP switches.

Channel Status LEDs

Channel status LEDs indicate the status for channels 0 through 3. Related error information is contained in the channel status word. This includes conditions such as:

- normal operation
- channel-related configuration errors
- open-circuit errors
- out-of-range errors

All channel errors are recoverable errors.

Module Status LED

The module status LED shows diagnostic or operating errors related to the module. These non-recoverable errors may be detected during power-up or during operation. Once an error has been detected, the module no longer communicates with the SLC processor. Channel states are disabled, and data words are cleared (0). Failure of any diagnostic test results in a non-recoverable error and requires the assistance of your local Allen-Bradley distributor or Rockwell Automation representative.

1747-NT4 Thermocouple Module Hardware Features

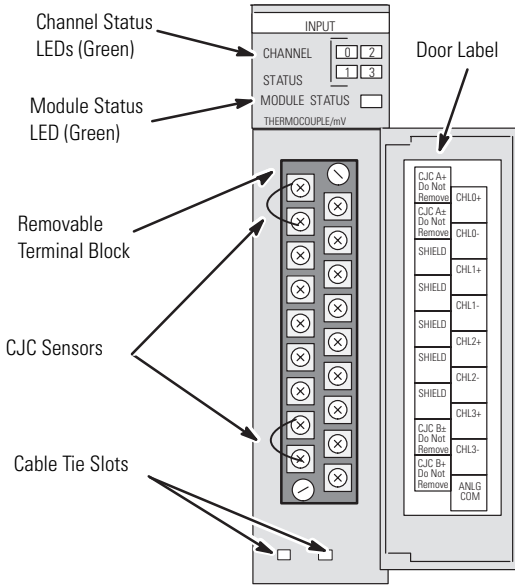

Required Tools and Equipment

Have the following tools and equipment ready:

- medium blade screwdriver
- medium cross-head screwdriver
- thermocouple or millivolt sensor
- appropriate thermocouple extension wire (if needed)
- thermocouple/mV input module (1746-NT4)
- programming equipment

Electrostatic Damage

Electrostatic discharge can damage semiconductor devices inside this module if you touch backplane connector pins. Guard against electrostatic damage by observing the following precautions.

ATTENTION



Electrostatic discharge can degrade performance or cause permanent damage. Handle the module as stated below.

- Wear an approved wrist strap grounding device when handling the module.
- Touch a grounded object to rid yourself of electrostatic charge before handling the module.
- Handle the module from the front, away from the backplane connector. Do not touch backplane connector pins.
- Keep the module in its static-shield bag when not in use, or during shipment.

NT4 Power Requirements

The thermocouple module receives its power through the SLC 500 chassis backplane from the fixed or modular +5V dc/+24V dc chassis power supply. The maximum current drawn by the module is shown in the table below.

5V dc Amps	24V dc Amps
0.060	0.040

When you are using a *modular system* configuration, add the values shown in the table above to the requirements of all other modules in the SLC chassis to prevent overloading the chassis power supply.

When you are using a *fixed system* controller, refer to the important note on page 8 about module compatibility in a 2-slot fixed expansion chassis.

Modular Chassis Considerations

Place your thermocouple module in any slot of an SLC 500 modular, or modular expansion chassis, except for the extreme left slot (slot 0) in the first chassis. This slot is reserved for the processor or adapter modules.

Fixed Expansion Chassis Considerations

IMPORTANT

The 2-slot, SLC 500 fixed I/O expansion chassis (1746-A2) will support only specific combinations of modules. If you are using the thermocouple module in a 2-slot expansion chassis with another SLC I/O or communication module, refer to the *SLC 500™ Thermocouple/mV Input Module User Manual*, 1746-6.6.1

General Considerations

Most applications require installation in an industrial enclosure to reduce the effects of electrical interference. Thermocouple inputs are highly susceptible to electrical noises due to the small amplitudes of their signal (microvolt/°C).

Group your modules to minimize adverse effects from radiated electrical noise and heat. Consider the following conditions when selecting a slot for the thermocouple module. Position the module:

- in a slot away from sources of electrical noise, such as hard-contact switches, relays, and AC motor drives
- away from modules which generate significant radiated heat, such as 32-point I/O modules

In addition, route shielded, twisted-pair thermocouple or millivolt input wiring away from any high-voltage I/O wiring.

Terminal Block Removal

When installing the module in a chassis, it is not necessary to remove the terminal block from the module. However, if the terminal block is removed, use the write-on label located on the side of the terminal block to identify the module location and type.

ATTENTION

Disconnect power to the SLC before attempting to install, remove, or wire the removable terminal wiring block.

To avoid cracking the removable terminal block, alternate the removal of the slotted terminal block release screws.

To remove the terminal block:

1. Loosen the two terminal block release screws.
2. Grasp the terminal block at the top and bottom and pull outward and down. When removing or installing the terminal block, be careful not to damage the CJC sensors.

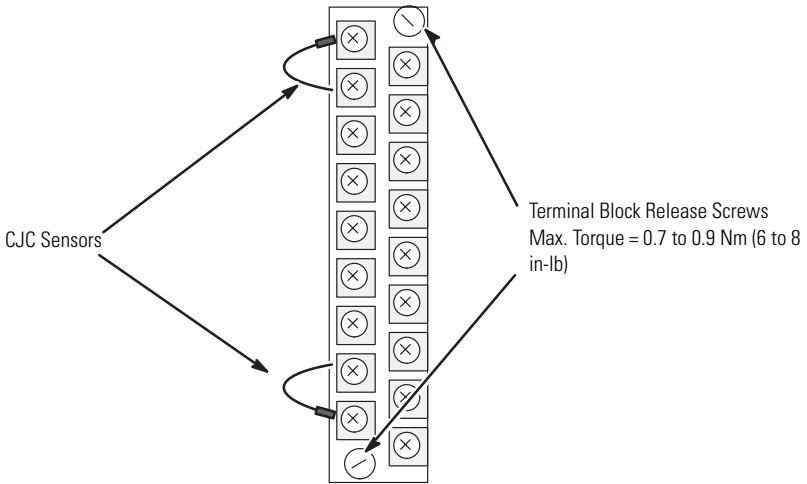

Module Installation and Removal

Module Installation Procedure

1. Align the circuit board of the thermocouple module with the card guides located at the top and bottom of the chassis.
2. Slide the module into the chassis until both top and bottom retaining clips are secured. Apply firm even pressure on the module to attach it to its backplane connector. Never force the module into the slot.
3. Cover all unused slots with the Card Slot Filler, Catalog Number 1746-N2.

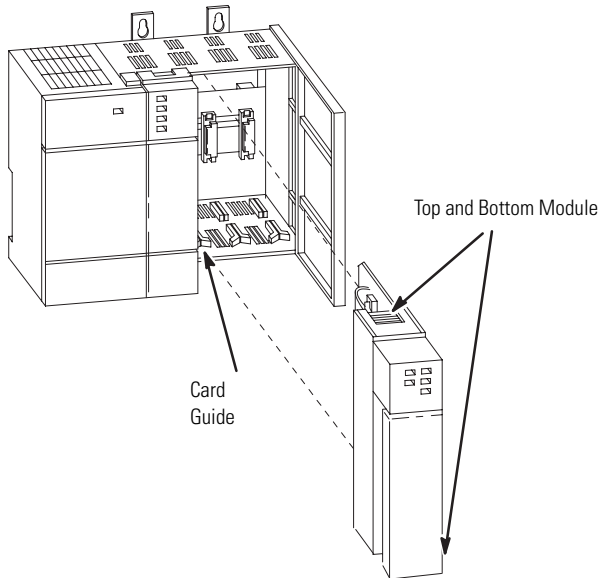

Module Removal Procedure

1. Press the releases at the top and bottom of the module and slide the module out of the chassis slot.
2. Cover all unused slots with the Card Slot Filler, Catalog Number 1746-N2.

Terminal Wiring

The thermocouple module contains a green, 18-position, removable terminal block. The terminal pin-out is shown below.

ATTENTION



Disconnect power to the SLC before attempting to install, remove, or wire the removable terminal wiring block.

(Terminal Block Spare Part Catalog Number 1746-RT32)

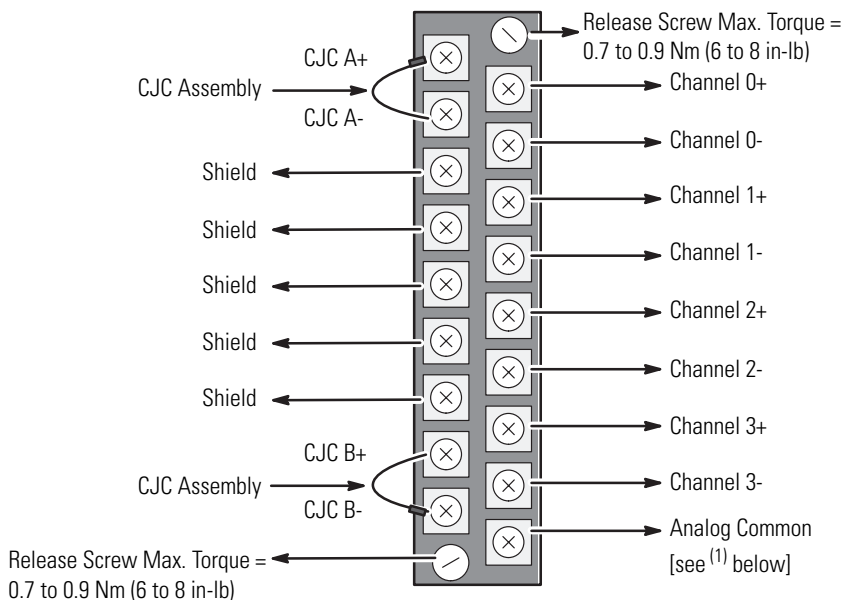

- (1) Replacing a Series A thermocouple module with a Series B module requires that the bottom right terminal (which was SHIELD on Series A modules) no longer be connected to CHASSIS GROUND if it was previously. Use one of the other SHIELD terminals.

Terminal screws accept a maximum of two #14 AWG (2 mm²) wires. Tighten terminal screws only tight enough to immobilize wires. Maximum torque on terminal screws is 0.7 to 0.9 Nm (6 to 8 in-lbs).

Thermocouple Junctions

There are three types of thermocouple junctions:

- *Grounded Junction* - The measuring junction is physically connected to the protective metal sheath providing electrical continuity between junction and sheath.
- *Ungrounded Junction* - The measuring junction is electrically isolated from the protective metal sheath. (Also called Insulated Junction.)
- *Exposed Junction* - Does not have a protective metal sheath so the measuring junction is exposed.

The illustration that follows shows each of the three thermocouple types.

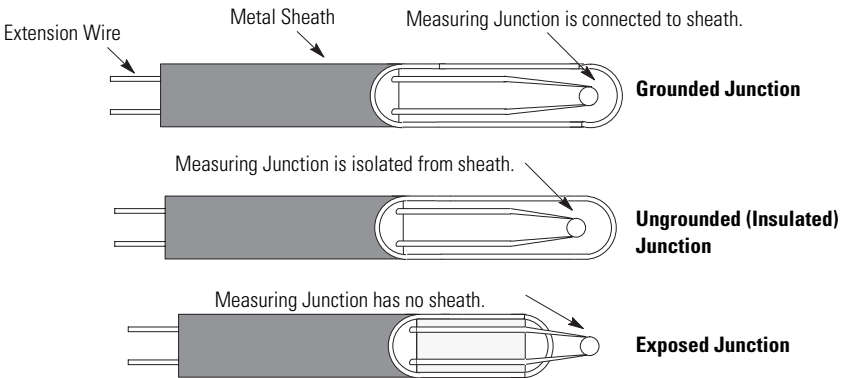

Wiring Considerations

ATTENTION

The possibility exists that grounded or exposed thermocouples can become shorted to a potential greater than that of the thermocouple itself. Due to possible shock hazard, care should be taken when wiring these types of thermocouples. See page 12 for definitions of thermocouple junctions.

Follow the guidelines below when planning your system wiring.

- To limit noise, keep thermocouple and millivolt signal wires as far away as possible from power and load lines.
- To ensure proper operation and high immunity to electrical noise, always use Belden™ 8761 (shielded, twisted-pair) or equivalent wire for millivolt sensors or shielded, twisted-pair thermocouple extension lead wire specified by the thermocouple manufacturer for the thermocouple type you are using. Using the incorrect thermocouple extension wire type or not following the correct polarity convention will cause invalid readings.
- Special considerations for using the analog common (**ANALOG COM**) terminal based on thermocouple type:
(See page 12 for an explanation of thermocouple junctions.)
 - When using grounded thermocouple(s), jumper the **ANALOG COM** terminal to any single active grounded channel's plus (+) or minus (-) terminal.
 - When using exposed thermocouple(s) that have the thermocouple junction touching an electrically conductive material, jumper the **ANALOG COM** terminal to any single active exposed channel's plus (+) or minus (-) terminal.
 - When using ungrounded (shielded) or exposed thermocouples that are not touching an electrically conductive material, do not use the **ANALOG COM** terminal.
 - When using a mix of grounded, ungrounded, and exposed thermocouples, jumper the **ANALOG COM** terminal to any single active grounded channel's plus (+) or minus (-) terminal.

- If millivolt inputs are used, the terminal should be biased to a level within 2V of the signal of interest. Use 10KΩ resistors to create a resistive voltage divider as shown in the following circuit diagram.

TIP

The Series A 1746-NT4 does not have an **ANALOG COM** terminal and cannot be used with multiple grounded and/or exposed thermocouples that touch electrically conductive material. The Series A can be used with a single grounded and/or exposed thermocouple that touches electrically conductive material, or multiple grounded thermocouples that have the protective sheath made of an electrically non-conductive material such as ceramic.

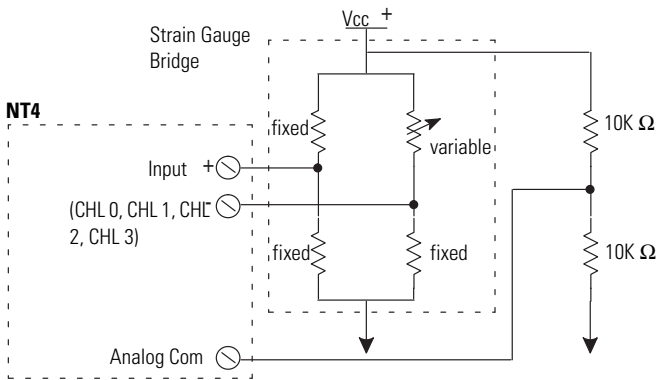

- Ground the shield drain wire at one end only. The preferred location is to the same point as the sensor ground reference.
 - For grounded thermocouples or mV sensors, this is at the sensor.
 - For insulated/ungrounded thermocouples, this is at the module.
 - Refer to IEEE Std. 518, Section 6.4.2.7 or contact your sensor manufacturer for additional details.
- If it is necessary to connect the shield at the module, each input channel has a convenient shield connection screw terminal that provides a connection to chassis ground. All shields are internally connected, so any shield terminal can be used with channels 0-3. For maximum noise reduction, one shield terminal must be connected to earth ground potential, i.e. mounting bolt on 1746 chassis.

- Tighten terminal screws using a flat or cross-head screwdriver. Each screw should be turned tight enough to immobilize the wire's end. Excessive tightening can strip the terminal screw. The torque applied to each screw should not exceed 6 - 8 in-lbs (0.7 - 0.9 Nm) for each terminal.
- The open thermocouple detection circuit injects approximately 12 nanoAmperes into the thermocouple cable. A total lead resistance of 25 Ω (12.5 one-way) will produce 0.3 mV of error. To reduce error, use large gauge wire with less resistance for long wire runs.
- Follow system grounding and wiring guidelines found in your *SLC 500 Installation and Operation Manual*, publication number 1747-6.21 (Fixed Hardware Style) or 1747-UM011 (Modular Hardware Style).

Wiring Input Devices to the NT4

After the thermocouple module is properly installed in the chassis, follow the wiring procedure below using the proper thermocouple extension cable, or Belden 8761 for non-thermocouple applications.

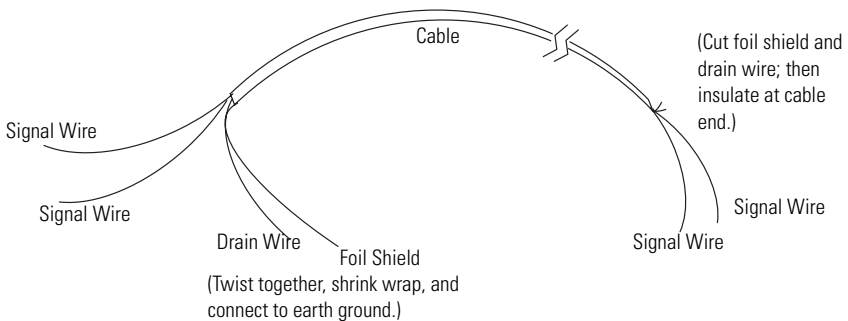

To wire your NT4 module, follow these steps.

1. At each end of the cable, strip some casing to expose the individual wires.
2. Trim the signal wires to 2-inch lengths. Strip about 4.76 mm (3/16 inch) of insulation away to expose the end of the wire.
3. At one end of the cable, twist the drain wire and foil shield together, bend them away from the cable, and apply shrink wrap. Then earth ground at the preferred location based on the type of sensor you are using (see wiring guidelines on page 13).

4. At the other end of the cable, cut the drain wire and foil shield back to the cable and apply shrink wrap.
5. Connect the signal wires to the NT4 terminal block and the input.
6. Repeat steps 1 through 5 for each channel on the NT4 module.

Cold-Junction Compensation (CJC)

ATTENTION



Do not remove or loosen the cold junction compensating thermistor assemblies located between the two upper and lower CJC terminals on the terminal block. *Both thermistor assemblies are critical to ensure accurate thermocouple input readings at each channel.* The module will not operate in the thermocouple mode if either assembly is removed.

To obtain accurate readings from each of the channels, the cold-junction temperature (temperature at the module's terminal junction between the thermocouple wire and the input channel) must be compensated for. Two cold-junction compensating thermistors have been integrated in the removable terminal block; they *must* remain installed to retain accuracy.

In case of accidental removal of either or both of the thermistor assemblies, make sure to replace them by connecting each one across the CJC terminals located at the top and bottom left side of the terminal block. When connecting the thermistor assembly at the top of the terminal block (between terminals CJC A+ and CJC A-), the lug containing the thermistor (marked with red epoxy) should attach to the uppermost screw terminal (CJC A+). When connecting the thermistor assembly at the bottom of the terminal block (between terminals CJC B+ and CJC B-), the lug containing the thermistor should attach to the lowermost screw terminal (CJC B+).

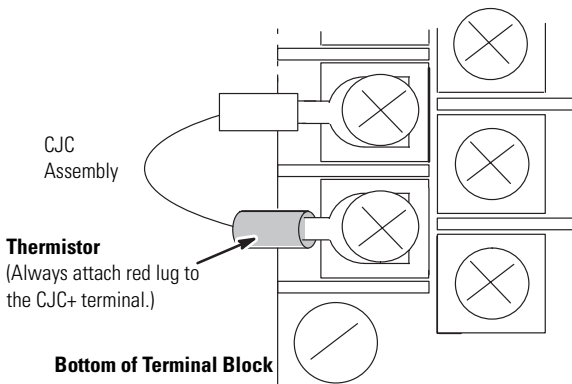

Module Addressing

The following memory map shows you how the output and input image tables are defined for the thermocouple module.

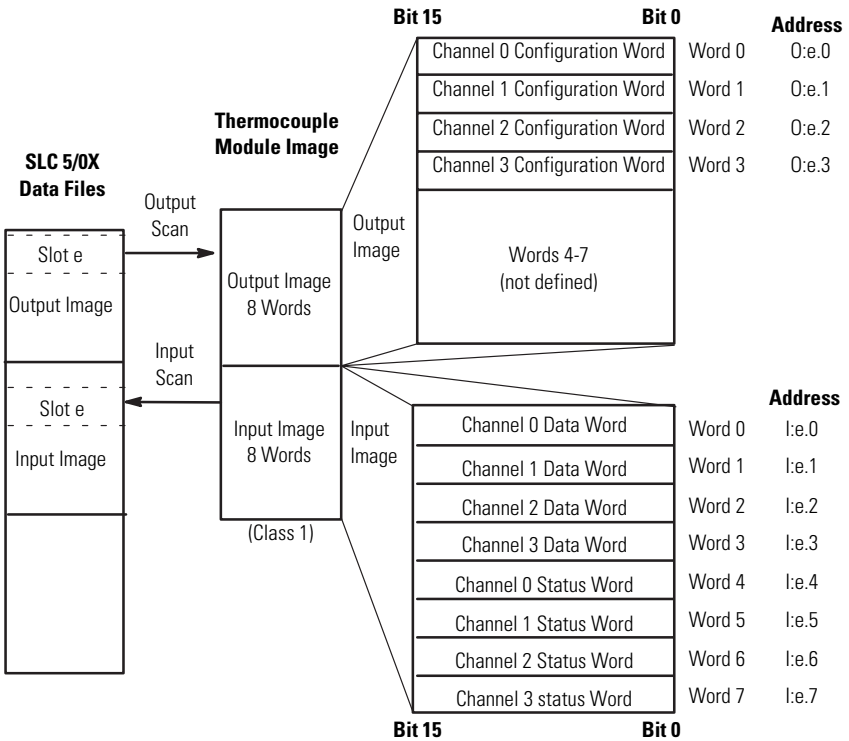

Channel Configuration

Once the module is installed, each channel on the module can be configured to establish the way the channel will operate. You configure the channel by entering bit values into the configuration word using your programming software. Channels 0 through 3 on the NT4 are configured by entering bit values into output words 0 through 3 respectively. Output words 4 through 7 are not used. See the table on page 18 for bit settings.

Channel Configuration Word - Bit Definitions

Define	To Select	Make these bit settings in the Channel Configuration Word ⁽¹⁾													
		15-12 ⁽²⁾	11	10	9	8	7	6	5	4	3	2	1	0	
Input type	Thermocouple Type J	Not Used										0	0	0	0
	Thermocouple Type K											0	0	0	1
	Thermocouple Type T											0	0	1	0
	Thermocouple Type E											0	0	1	1
	Thermocouple Type R											0	1	0	0
	Thermocouple Type S											0	1	0	1
	Thermocouple Type B											0	1	1	0
	Thermocouple Type N											0	1	1	1
	±50mV											1	0	0	0
	±100mV											1	0	0	1
	CJC temperature											1	1	1	1
Data format	Engineering units 1 ⁽³⁾									0	0				
	Engineering units 10 ⁽⁴⁾									0	1				
	Scaled-for-PID									1	0				
	Proportional Counts								1	1					
Open circuit	Zero						0	0							
	Upscale						0	1							
	Downscale						1	0							
Temperature units	Degrees C ⁽⁵⁾				0										
	Degrees F ⁽⁵⁾				1										
Channel filter frequency	10 Hz		0	0											
	50 Hz		0	1											
	60 Hz		1	0											
	250 Hz		1	1											
Channel enable	Channel Disabled	0													
	Channel Enabled	1													

- (1) Bit settings other than those shown in the table are invalid.
- (2) Ensure unused bits 12-15 are always set to zeros.
- (3) For engineering units x 1, values are expressed in 0.1 degrees or 0.01 mV.
- (4) For engineering units x 10, values are expressed in 1.0 degrees or 0.1 mV.
- (5) When millivolt input type is selected, the bit setting for temperature units is ignored.

Specifications

Electrical Specifications

Backplane Current Consumption	60 mA at 5V dc
	40 mA at 24V dc
Backplane Power Consumption	1.3W maximum (0.3W at 5V dc, 1.0W at 24V dc)
Number of Channels	4 (backplane isolated)
I/O Chassis Location	Any I/O module slot except slot 0
A/D Conversion Method	Sigma-Delta Modulation
Input Filtering	Low pass digital filter with programmable notch (filter) frequencies
Normal Mode Rejection (between [+] input and [-] input)	Greater than 100 dB at 50 Hz (10 Hz, 50 Hz filter frequencies)
	Greater than 100 dB at 60 Hz (10 Hz, 60 Hz filter frequencies)
Common Mode Rejection (between inputs and chassis ground)	Greater than 150 dB at 50 Hz (10 Hz, 50 Hz filter frequencies)
	Greater than 150 dB at 60 Hz (10 Hz, 60 Hz filter frequencies)
Input Filter Cut-Off Frequencies	2.62 Hz at 10 Hz filter frequency
	13.1 Hz at 50 Hz filter frequency
	15.72 Hz at 60 Hz filter frequency
	65.5 Hz at 250 Hz filter frequency
Calibration	Module autocalibrates at powerup and whenever a channel is enabled.
Isolation	500V dc one minute between inputs and chassis ground, and between inputs and backplane.
Maximum Channel-to-Channel Common-Mode Separation	Series B or later: 2V maximum between any two channels Series A: 0V separation

Physical Specifications

LED Indicators	5 green status indicators, one for each of 4 channels and one for module status
Module ID Code	3510
Recommended Cable:	
for thermocouple inputs	Appropriate shielded, twisted-pair thermocouple extension wire ⁽¹⁾
for mV inputs	Belden #8761 or equivalent
Maximum Wire Size	Two 14 AWG wires per terminal
Maximum Cable Impedance	25 ohms maximum loop impedance, for <1LSB error
Removable Terminal Strip	Allen-Bradley spare part Catalog Number 1746-RT32

(1) Refer to the thermocouple manufacturer for the correct extension wire.

Environmental Specifications

Operating Temperature	0°C to +60°C (+32°F to +140°F) ⁽¹⁾
Storage Temperature	-40°C to +85°C (-40°F to +185°F)
Relative Humidity	5% to 95% (without condensation)
Certification	UL listed
	CSA approved
	Class I, Division 2, Groups A, B, C, D
	CE compliant for all applicable directives when product or packaging is marked

(1) When the NT4 module detects zero degrees (+/- 3°) at the CJC, it will detect an out of range condition and set values to downscale -270°C (-454°F). It is recommended that ambient temperature surrounding the SLC 500 system be maintained above 3°C (37.4°F) in order for the NT4 module to measure temperature correctly without detecting an out of range condition.

Thermocouple Temperature and Millivolt Input Ranges

Input Type	Temperature Range
Thermocouple Type J	-210°C to +760°C (-346°F to +1400°F)
Thermocouple Type K	-270°C to +1370°C (-454°F to +2498°F)
Thermocouple Type T	-270°C to +400°C (-454°F to +752°F)
Thermocouple Type E	-270°C to +1000°C (-454°F to +1832°F)
Thermocouple Type R	0°C to +1768°C (+32°F to +3214°F)
Thermocouple Type S	0°C to +1768°C (+32°F to +3214°F)
Thermocouple Type B	+300°C to +1820°C (+572°F to +3308°F)
Thermocouple Type N	0°C to +1300°C (+32°F to +2372°F)
Millivolt Input: -50 mV dc to +50 mV dc	
Millivolt Input: -100 mV dc to +100 mV dc	

Input Specifications

Thermocouple Linearization	IPTS-68 standard, NBS MN-125, NBS MN-161
Cold-Junction Compensation	Accuracy $\pm 1.5^{\circ}\text{C}$, 0°C to $+85^{\circ}\text{C}$ ($+32^{\circ}\text{F}$ to $+185^{\circ}\text{F}$)
Input Impedance	Greater than $10\text{M}\Omega$
Temperature Scale (Selectable)	$^{\circ}\text{C}$ or $^{\circ}\text{F}$ and 0.1°C or 0.1°F
DC Millivolt Scale (Selectable)	0.1 mV or 0.01 mV
Open Circuit Detection Leakage Current	12 nA maximum
Open Circuit Detection Method	Upscale
Module Update Time	The sum of all enabled channel's sample times plus one CJC update time. See channel sampling time table on page 22.
Channel Turn-On Time, Reconfiguration Time	Requires up to one module update time plus one of the following: <ul style="list-style-type: none"> • 250 Hz Filter = 82 milliseconds • 60 Hz Filter = 196 milliseconds • 50 Hz Filter = 226 milliseconds • 10 Hz Filter = 946 milliseconds
Channel Turn-Off Time	Requires up to one module update time
Time to Detect Open Circuit	500 msec or 1 module update time, whichever is greater

Thermocouple/mV Input Module Accuracy

Input Type	With Autocalibration ⁽¹⁾		Without Autocalibration ⁽¹⁾
	Maximum Error at +25°C	Maximum Error at +77°F	Temperature Drift (0°C to +60°C)
J	±1.06°C	±1.91°F	±0.0193°C/°C, °F/°F
K	±1.72°C	±3.10°F	±0.0328°C/°C, °F/°F
T	±1.43°C	±2.57°F	±0.0202°C/°C, °F/°F
E	±0.72°C	±1.3°F	±0.0190°C/°C, °F/°F
S	±3.61°C	±6.5°F	±0.0530°C/°C, °F/°F
R	±3.59°C	±6.46°F	±0.0530°C/°C, °F/°F
B	±3.12°C	±5.62°F	±0.0457°C/°C, °F/°F
N	±1.39°C	±2.5°F	±0.0260°C/°C, °F/°F
±50 mV	±50 µV	±50 µV	±1.0 µV/°C, ±1.8 µV/°F
±100 mV	±50 µV	±50 µV	±1.5 µV/°C, ±2.7 µV/°F

(1) Assumes the module terminal block temperature is stable.

Filter Frequency and Step Response Time

Filter Frequency	50 Hz NMR ⁽¹⁾	60 Hz NMR ¹	Cut-Off Frequency	Step Response
10 Hz	100 dB	100 dB	2.62 Hz	300 msec
50 Hz	100 dB	-	13.1 Hz	60 msec
60 Hz	-	100 dB	15.72 Hz	50 msec
250 Hz	-	-	65.5 Hz	12 msec

(1) Normal Mode Rejection

Channel Sampling Time for Each Filter Frequency

CJC Update Time	Channel Sampling Time ⁽¹⁾			
	250 Hz Filter	60 Hz Filter	50 Hz Filter	10 Hz Filter
14 msec	12 msec	50 msec	60 msec	300 msec

(1) all values ±1 msec

Rockwell Automation Support

Rockwell Automation provides technical information on the Web to assist you in using its products. At <http://support.rockwellautomation.com>, you can find technical manuals, a knowledge base of FAQs, technical and application notes, sample code and links to software service packs, and a MySupport feature that you can customize to make the best use of these tools.

For an additional level of technical phone support for installation, configuration, and troubleshooting, we offer TechConnect Support programs. For more information, contact your local distributor or Rockwell Automation representative, or visit <http://support.rockwellautomation.com>.

Installation Assistance

If you experience a problem with a hardware module within the first 24 hours of installation, please review the information that's contained in this manual. You can also contact a special Customer Support number for initial help in getting your module up and running.

United States	1.440.646.3223 Monday – Friday, 8am – 5pm EST
Outside United States	Please contact your local Rockwell Automation representative for any technical support issues.

New Product Satisfaction Return

Rockwell tests all of its products to ensure that they are fully operational when shipped from the manufacturing facility. However, if your product is not functioning, it may need to be returned.

United States	Contact your distributor. You must provide a Customer Support case number (see phone number above to obtain one) to your distributor in order to complete the return process.
Outside United States	Please contact your local Rockwell Automation representative for return procedure.

Rockwell Automation, Allen-Bradley, SLC, and TechConnect are trademarks of Rockwell Automation, Inc.

Trademarks not belonging to Rockwell Automation are property of their respective companies.

www.rockwellautomation.com

Power, Control and Information Solutions Headquarters

Americas: Rockwell Automation, 1201 South Second Street, Milwaukee, WI 53204-2496 USA, Tel: (1) 414.382.2000, Fax: (1) 414.382.4444

Europe/Middle East/Africa: Rockwell Automation, Vorstlaan/Boulevard du Souverain 36, 1170 Brussels, Belgium, Tel: (32) 2 663 0600, Fax: (32) 2 663 0640

Asia Pacific: Rockwell Automation, Level 14, Core F, Cyberport 3, 100 Cyberport Road, Hong Kong, Tel: (852) 2887 4788, Fax: (852) 2508 1846

Publication 1746-IN010D-EN-P - June 2004

PN 40071-139-01(4)

Supersedes Publication 1746-IN010C-EN-P - November 2002

Copyright © 2007 Rockwell Automation, Inc. All rights reserved. Printed in Singapore.